

RIPTIDE 45/V/T 36" PARTS DIAGRAM

12 volts 42 amps

for use with "P" serial numbers

2-year warranty

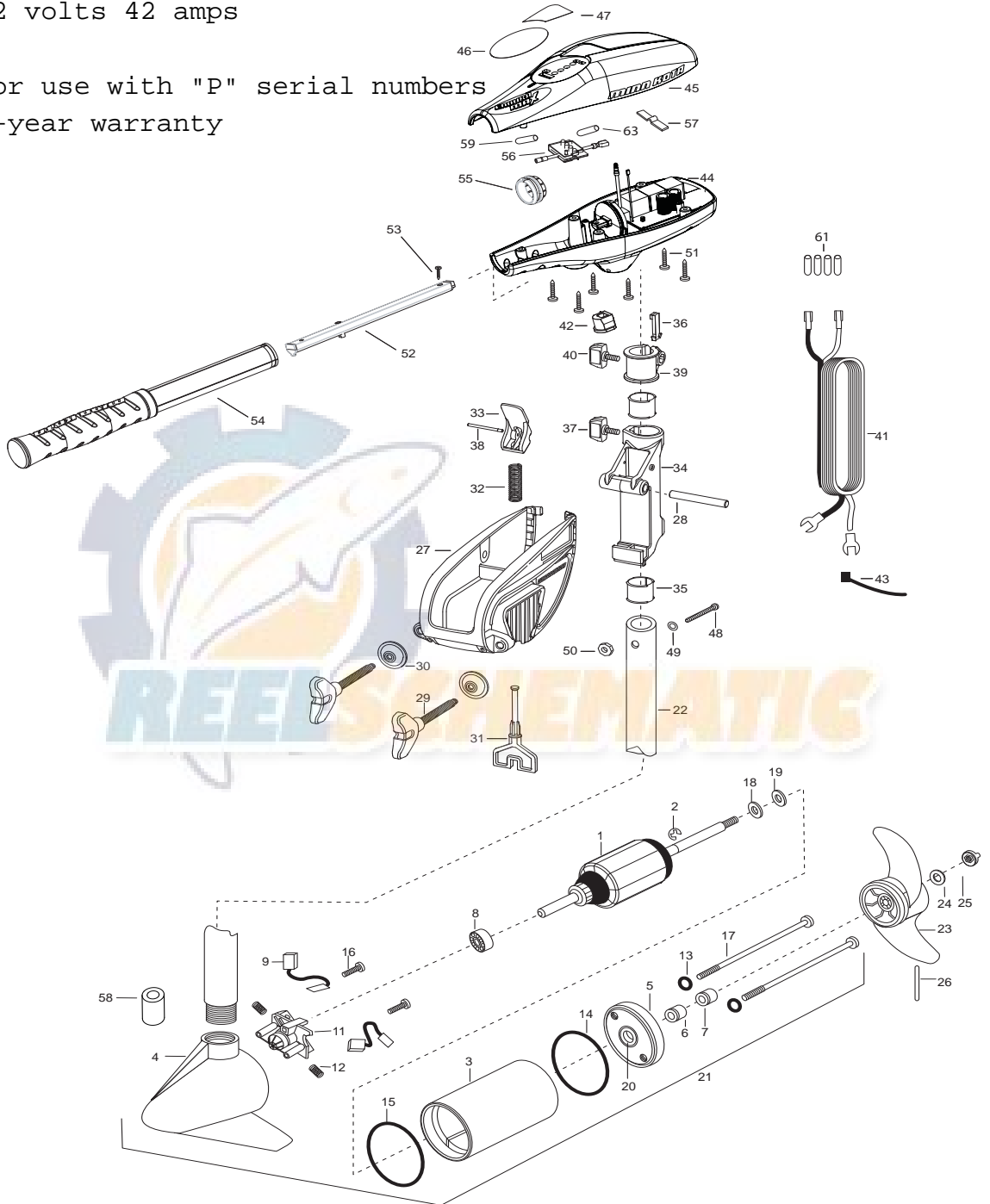

RIPTIDE 45/V/T 36" PARTS LIST

Item	Part Number	Description	Item	Part Number	Description
1	2-100-202	ARMATURE ASSEMBLY 12v 3.25	*30	2331700	WASHER-CLAMP SCREW, SS [2.EA]
2	788-015	RETAINING RING	31	2063605	T-BAR, PLASTIC
3	2-200-379	HOUSING ASSEMBLY CENTER 3.25 TXT	32	2062706	SPRING- (T-BAR)
4	421-332	BRUSH END HOUSING ASSEMBLY 3.25	33	2067201	LEVER-TILT BLACK
5	2-400-328	PLAIN END HOUSING ASSEMBLY 3.25	34	2061810	HINGES-PLASTIC
6	880-003	SEAL	35	2037301	BUSHING-HINGE [2.EA]
7	880-006	SEAL W/SHIELD	36	2062800	TENSION BLOCK-SNAP IN
8	140-010	BALL BEARING	37	2011386	SCREW, TENSION/KNOB, SS
9	188-052	BRUSH ASSEMBLY [2.EA]	38	2060516	PIN, TILT LEVER, SS
11	738-030	BRUSH PLATE W/HOLDER 3.25	39	2061520	COLLAR-DEPTH
12	975-032	SPRING-COMPRESSION [2.EA]	40	2011366	SCREW-COLLAR/NEW KNOB, SS
■	2883460	SEAL AND O RING KIT	41	2050609	LEADWIRE
13	701-007	O-RING- THRU BOLT [2.EA]	42	2062905	STRAIN RELIEF
14	701-039	O-RING	43	2026300	TIE WRAP
15	701-041	O-RING	44	2994041	CONTROL BOX, WHITE
16	830-001	SCREW- SELF THREAD 8-32X1.7 [2.EA]	45	2060226	CONTROL BOX COVER, WHITE
17	830-078	THRU BOLT 8-32X8.0 [2.EA]	46	2095633	DECAL COVER, RT 45/VS/T
18	990-067	WASHER- STEEL THRUST	47	2095636	COVER DECAL, RT/VS/T
19	990-070	WASHER- NYLATRON [AS REQUIRED]	48	2033403	SCREW-10-24 X 1-3/4, SS
20	144-049	FLANGE BEARING (SERVICE ONLY)	49	2061720	WASHER-NYLON, 3/8 OD, 3/16 ID
21	2069290	MOTOR ASSEMBLY 12 V 3.25 VARIABLE SPD SW	50	2333101	NUT-10-24 HEX, SS
22	2002021	TUBE-COMPOSITE, WHITE 36"	51	2372100	SCREW-8-18 X 5/8, SS [6.EA]
■	1378121	PROP W/DRIVE PIN, WASHER, NUT KIT	52	2990924	INNER HANDLE ASSEMBLY
23	2061122	PROPELLER 3.25 HUB DIA	53	2012104	SCREW-#6 x 1/2" SS
24	2151726	WASHER- 5/16 STD SS	54	2990952	OUTER HANDLE ASSEMBLY
25	2198400	NUT-PROP NYLOCK (MED) SS ANODE	55	2060009	FRONT BEARING
26	2092600	PIN-DRIVE	56	2074080	BATTERY METER 12V
■	2771816	BRACKET & HINGE ASSEMBLY (INCLUDES 27-38)	57	2302742	SPRING DETENT, OFF
■	2771913	BRACKET ASSEMBLY (INCLUDES 27, 29, 30)	58	2307312	FERRITE BEAD
*27	2061910	BRACKET	59	2305415	SHRINK TUBE - .472 ID x 2.25"
28	2060511	PIN-HINGE, SS	60	2305410	SHRINK TUBE - .315 OD x 2.25"
*29	2061301	SCREW-CLAM, SS [2.EA]	61	2305403	SHRINK TUBE - .500 ID 1.0" ADHSV

* This item is part of an assembly. This item cannot be sold separately due to machining and/or assembly that is required.

WIRING DIAGRAM

